

**GRADEN**<sup>®</sup>  
INDUSTRIES

---

# GS04 VERTICUTTER/SCARIFIER

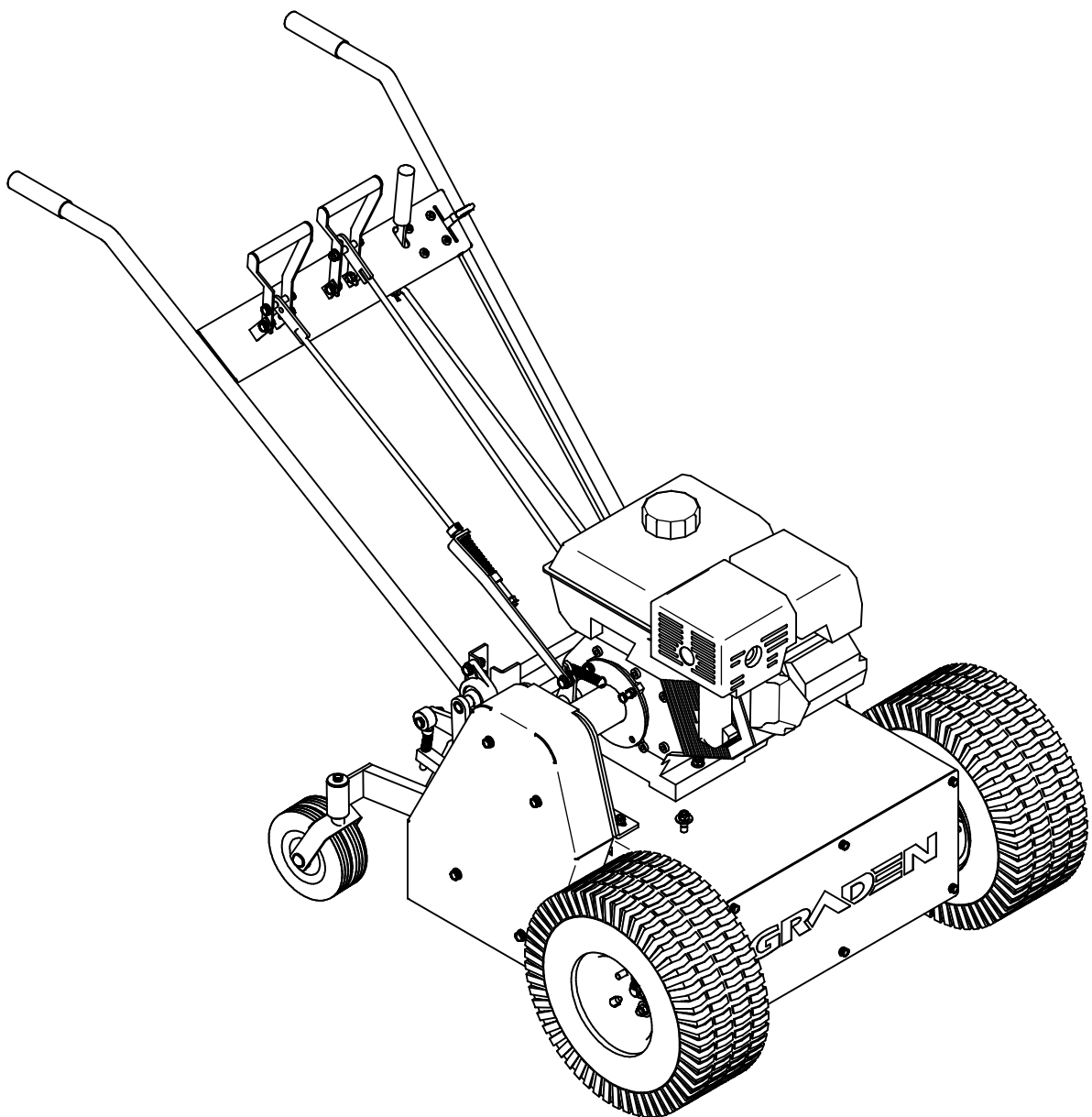

*Owner's Manual*

## **GRADEN TURF MACHINERY**

Manufactured under licence by

### **Turf Machinery**

1 Waitchie Street

Wedderburn 3518

Victoria Australia

Tel - (03) 5494 3059

Web - [gradienturfmachinery.com](http://gradienturfmachinery.com)

Email - [turf.engineering@bigpond.com](mailto:turf.engineering@bigpond.com)

Contact - Geoff Burnside geoff@turf.com.au

# **Table of Contents**

## **1. Specifications**

## **2. To the Owner**

- 2.1 Preliminary Instructions
- 2.2 Warning Symbols
- 2.3 Servicing the Verticutter

## **3. Safety Information**

- 3.1 General Rules
- 3.2 Training
- 3.3 Personal Protective Equipment (PPE)
- 3.4 Preparation
- 3.5 Operational Safety
- 3.6 Maintenance Safety

## **4. Controls**

- 4.1 Pulley Clutch Handle
- 4.2 Lifting / Lowering Handle
- 4.3 Motion Lever
- 4.4 Engine Lever
- 4.5 Neutral Lever

## **5. Operating Instructions**

- 5.1 Preliminary Checks
- 5.2 Start Up
- 5.3 Driving (Traversing) the Verticutter
- 5.4 Verticutting
- 5.5 Shut Down

## **6. Maintenance Operations**

- 6.1 Adjustments and Settings
  - 6.1.1 Rotor Belts
  - 6.1.2 Gearbox Drive Belt
  - 6.1.3 Transmission Drive Belt
- 6.2 Replacements
  - 6.2.1 Blade Replacement
  - 6.2.2 Belt Replacement
- 6.3 Engine Maintenance
- 6.4 Maintenance Schedule

## **7. Diagrams**

## **8. Warning Decals**

# 1. Specifications

|                                |  |
|--------------------------------|--|
| <b>Model</b>                   | <b>Graden GS04 Verticutter/Scarifier</b> |
| <b>Engine</b>                  | Honda GX390                              |
| <b>Power</b>                   | 13hp Horizontal shaft                    |
| <b>Engine Oil</b>              | 1.1 litres SAE 30W Grade                 |
| <b>Fuel</b>                    | Unleaded 86 RON (minimum)                |
| <b>Transmission Oil</b>        | SAE 30W Grade                            |
| <b>Cutting Width</b>           | 400mm                                    |
| <b>Cutting Depth</b>           | 0-45mm (maximum with standard blades)    |
| <b>Blades</b>                  | Tungsten carbide tipped spring steel     |
| <b>Blade Size</b>              |  |
| <b>Part Number 0048</b>        | 190mm Diameter – 2mm tip (Standard)      |
| <b>Part Number 0381</b>        | 190mm Diameter – 1mm tip (Optional)      |
| <b>Part Number 0049</b>        | 190mm Diameter - 3mm tip (Optional)      |
| <b>Blade Tip Speed</b>         | 2150m/min at 3600 rpm                    |
| <b>Weight</b>                  | 165 kg                                   |
| <b>Width</b>                   | 840mm                                    |
| <b>Tyres</b>                   | 15 x 6.00 / 6                            |
| <b>Tyre Pressure</b>           | 95 kPa (14 psi)                          |
| <b>Rotor Belts</b>             | AP40 Gates Predator V-Belt               |
| <b>Gearbox Drive Belt</b>      | A27 Gates V-Belt                         |
| <b>Transmission Drive Belt</b> | A29 Gates V-Belt                         |

## **2. To the Owner**

**Read this manual before operating the Verticutter**

### **2.1 Preliminary Instructions**

- It is important that the owner completely familiarises themselves with the contents of this manual
- Keep this manual at hand as a ready reference for anybody using the Graden GS 04 Verticutter
- The designed and tested safety features of this machine are dependent on it being operated within the limitations described in this manual

### **2.2 Warning Symbols**

Throughout this manual the following symbols are used to indicate important safety issues. When either or both of these symbols are present the operator must be aware that there is the potential to damage equipment and/or incur serious personal injury.

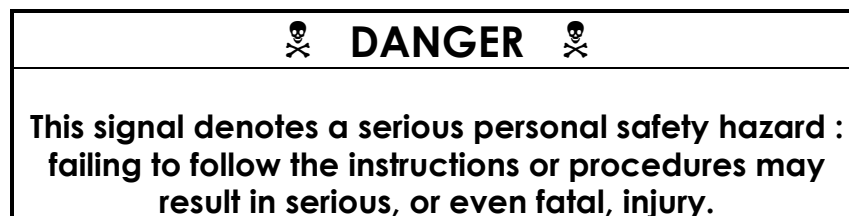
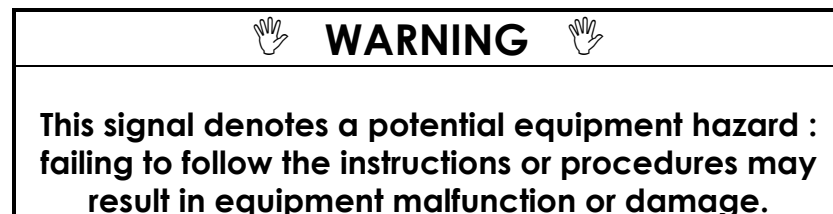

## **2.3 Servicing the Verticutter**

The Graden Verticutter has been carefully engineered and manufactured to provide safe, dependable and effective service.

As with all mechanical equipment it requires routine cleaning and maintenance.

Your authorised Graden representative has access to tools, genuine spares and equipment to service any and all of your requirements.

Use only genuine Graden parts; substitute parts will void the warranty and may not meet the safety and performance standards required for safe and effective operation of the Verticutter.

Please record the model and serial numbers of the Verticutter in the space provided below and quote this information when ordering parts or communicating with Graden Industries or its' approved representatives.

**Model Number :** \_\_\_\_\_

**Serial Number :** \_\_\_\_\_

**Date Purchased :** \_\_\_\_\_

### **3. Safety Information**

This manual is provided to help you operate and maintain the Verticutter. Please read it carefully.

It has been compiled from extensive field experience and engineering data.

In some aspects it is generalised because it is impossible to cover all operating scenarios. However, combining the information provided in this manual with your own increasing experience and knowledge with the Verticutter will enable you to develop procedures suitable for your individual needs.

The Verticutter, like most modern machinery, is constantly undergoing development on the basis of experience and market needs. At the time of printing, material in this manual was current but may vary due to the aforementioned ongoing development.

Graden Industries reserve the right to change the machinery specifications without notice.

#### **3.1 General Rules**

- Direction on the machine (right or left) is determined from standing behind the handles and facing in the direction of forward travel
- When viewed from the right side the blades rotate anti-clockwise (counter rotating to the forward rotation of the front drive wheels)
- This is a precision piece of machinery with high speed cutting blades

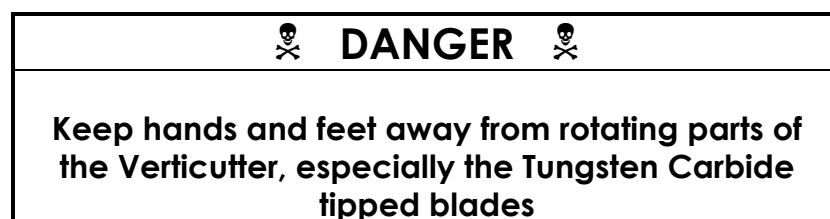

- Do not allow children to operate the machine or be near it during its operation.
- Only people who are very familiar with the rules of safe operation should be allowed to use this machine
- Only use the machine during daylight or in good artificial light
- Some diagrams in this manual show the Verticutter with safety guards removed. This is not a normal situation !



### 3.2 Training



- Do not allow anybody to operate the machine without instruction
- Know your controls and how to stop the machine and shut down the engine quickly in an emergency
- To maintain control and reduce the possibility of upset, damage or collision, operate the machine smoothly. Avoid erratic operation and excessive speed.





- Be aware of the hazards associated with the engine :
  - ⇒ Petrol is highly flammable so only use an appropriate container
  - ⇒ Never remove the fuel cap or add fuel while the engine is running or still hot
  - ⇒ Never add fuel indoors and wipe up any spillages
  - ⇒ Never run the engine in an enclosed area because exhaust gases are toxic

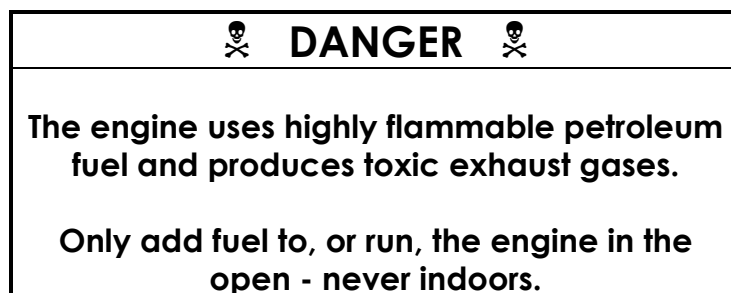

### **3.3 Personal Protective Equipment (PPE)**

- Clothing should be reasonably snug fitting and not free flowing so as to avoid the risk of entanglement in moving parts.
- Wear sturdy footwear, preferably steel capped safety shoes or boots
- Use appropriate PPE for eyes, ears and hands

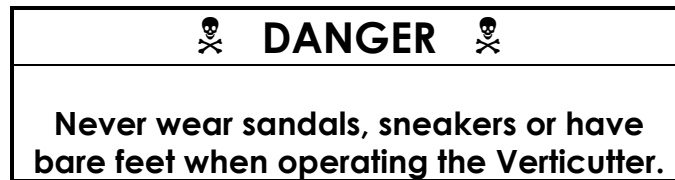

### **3.4 Preparation**

- Ensure all safety warnings and decals are in place and legible.
- Remove any accumulated debris that might represent a fire hazard.
- Ensure that the blades are in a serviceable condition and that the rotor shaft mounting bolts are secure.
- Perform any appropriate scheduled maintenance before starting the machine.

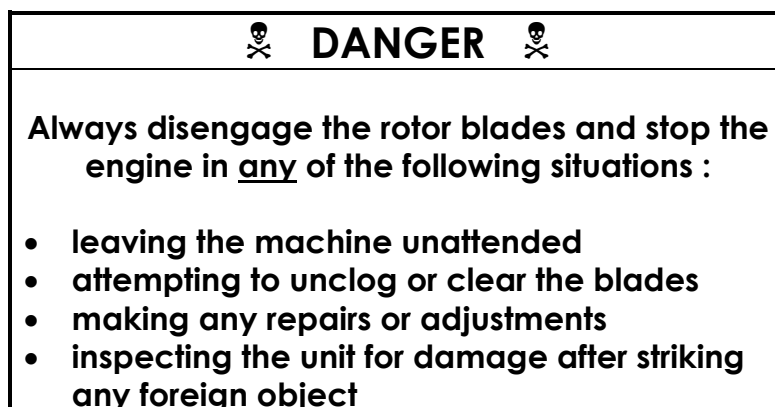

### **3.5 Operational Safety**

- Always disengage the rotor blades before attempting to start the Verticutter.
- Always raise the rotor blades before attempting to start the machine.
- Always disengage the blades and raise them when crossing gravel, walkways, roads, etc.. or indeed any ground which you do not wish to cut.





- Always repair any damage before recommencing operation.

### 3.6 Maintenance Safety

|   |
|---|
|  <b>DANGER</b>  |
| <b>Raise blades clear of turf or surface, disengage blades and turn off the engine before carrying out any maintenance or servicing.</b>  |

- Never allow anybody to start the engine while adjustments, maintenance or servicing are being performed.
- Keep machine free of any debris
- Remove debris from underneath the Verticutter after each use.
- Verify that all warning labels and decals are present, visible and legible.
- Periodically check that all bolts, fasteners and catches are secure and in safe operating condition.
- After any maintenance or servicing, ensure that all guards and safety devices are correctly installed and secure before operating the Verticutter.

|   |
|---|
|  <b>DANGER</b>  |
| <b>Frequently check the rotor blades. Verify that all the tips are in good condition.</b>   |
| <b>Ensure that the blades are firmly held and there is no slack due to damaged or worn spacers.</b>   |

## **4. Controls**

Please refer to the diagrams. All directions are given with reference to standing behind the handles and facing in the direction of forward travel.

### **4.1 Pulley Clutch Handle**

This handle engages the rotor blades.

To engage the blades pull the pulley clutch handle (0031) towards you gently and smoothly until it locks down in position against the control panel. To disengage simply push the handle away from you. You should engage the blades before lowering them into the turf.

### **4.2 Lifting/Lowering Handle**

This lever lowers and raises the blades out of the turf.

The blades should be engaged before lowering them into the turf - this avoids undue stress on the rotor belts and engine.

To lower, take the weight of the machine by the hand grips and then slowly push the handle (0030) forward.

Gently allow the weight of the Verticutter to take the blades into the turf.

### **4.3 Motion Lever**

This lever controls forward and reverse motion of the Verticutter.

There is the neutral position as indicated by the sticker beside the lever on the controls panel. Push the motion lever (0382) forwards and the machine travels forward at a rate depending on how far the lever is pushed.

Maximum speed corresponds to a brisk walking pace.

Pulling the lever towards you causes the machine to travel in reverse.

Maximum reverse speed is less than half of the maximum forward speed for safety reasons.

### **4.4 Engine Lever**

Controls rpm of the engine.

Fully forward is the idle position.

Pulling the lever towards you increases the speed of the engine.

Verticutting should be carried out at high engine speed to give high tip speed and therefore a better cut.

### **4.5 Neutral Lever**

This small plated lever is located on the left side of the machine, behind the drive wheel and has two positions;

NEUTRAL : allows the machine to be pushed manually

DRIVE : engages the transmission for normal operation

The Verticutter can only be started in the NEUTRAL position.

## **5. Operating Instructions**



### **5.1 Preliminary Checks**

1. Clear any debris from above and underneath the machine
2. Ensure scheduled maintenance activities have been completed.
3. Inspect belts for condition and correct tension.
4. Inspect blades for wear or damage.
5. Ensure all guards and covers are firmly fixed in place.
6. Check engine oil level ; change according to manufacturer's recommendations.

### **5.2 Start Up**

1. Check that blades are disengaged - push the pulley clutch handle all the way forward.
2. Check that the blades are in the raised position - pull Lifting/lowering handle towards you and ensure that it locks into position
3. Check that motion lever is in NEUTRAL position.
4. Move neutral lever (left side of machine) to NEUTRAL.
5. Turn engine switch to ON.
6. Move fuel valve lever to the ON position
7. Operate the choke lever in the direction of the arrow (i.e. closed)
8. Slide the engine lever about 1/3 of the way toward the FAST position
9. Pull the recoil starter grip lightly until resistance is felt, then pull briskly. Return the starter grip gently. Repeat until engine starts.
10. Progressively slide the choke lever back to the open position as the engine warms up.

### **5.3 Driving (Traversing) the Verticutter**

1. Move the neutral lever (left side of machine) to DRIVE.
2. Use the motion lever to move in the desired direction. Push the lever forward (away from you) to move forward ; pull the lever toward you to reverse. Maximum reverse speed is considerably slower than maximum forward speed.
3. Speed is controlled by the pressure applied to the motion lever.

## **5.4 Verticutting**

1. Select the depth of cut via the height adjustment knob (0218). Normal range of cut (with standard 190mm blades) is 15mm to 38 mm deep. One revolution of the knob is approximately equivalent to 1mm change in the cutting depth. Clockwise rotation of the knob means a shallower cut; anti-clockwise means a deeper cut.
2. Increase engine speed to maximum rpm; maximum engine speed results in a high blade tip speed and a cleaner cut.
3. Engage the blades by slowly pulling the pulley clutch handle toward you.
4. Lower the blades into the turf by taking some of the weight of the machine by lifting the handles and then slowly pushing the lifting / lowering handle forward. Allow the weight of the Verticutter to take the blades into the turf.
5. Move the motion lever forward until you are moving at the desired speed.
6. Steer the machine in a straight line while the blades are cutting. Trying to change direction while the blades are in the turf may lead to a furrowing/scalping action and can put undue stress on the blades.
7. At the end of a pass:
  - move the motion lever to NEUTRAL
  - raise the blades by pulling the lifting/lowering handle towards you
  - turn the Verticutter around to make your next run
  - repeat from Step 4 onwards

When travelling from area to area raise the blades and disengage the blades.

## **5.5 Shut Down**

1. Move the motion lever to NEUTRAL
2. Raise the blades out of turf.
3. Disengage blades.
4. Traverse machine to storage/maintenance area.
5. Turn engine speed to idle.
6. Turn engine switch to OFF.
7. Slide petrol lever to OFF.
8. Clear rotor blades of any debris.
9. Clear bottom of transmission, ensuring cooling fins are not clogged.
10. Generally clean the Verticutter, making sure that there is no accumulated debris around the engine.

## 6. Maintenance Operations

The performance of certain maintenance, adjustment or repair operations will be determined by the owner's facilities.

Tilting of the machine for the purpose of under-deck servicing should be done with great care.

If the Verticutter is tilted forward (i.e. pivoting over the front axle) there is a risk that engine oil can enter the cylinder head of the engine and transmission oil can leak from the breather located on top of the transmission.

Either occurrence can result in expensive repairs to the machine



For the purpose of under-deck servicing, tilting the machine back so that it rests on its handles is acceptable provided that the following precautions are taken :

1. Turn the swivel wheel brackets (0035) around so that the rear wheels are facing forward.
2. Lift the front of the machine up until the handles contact the ground

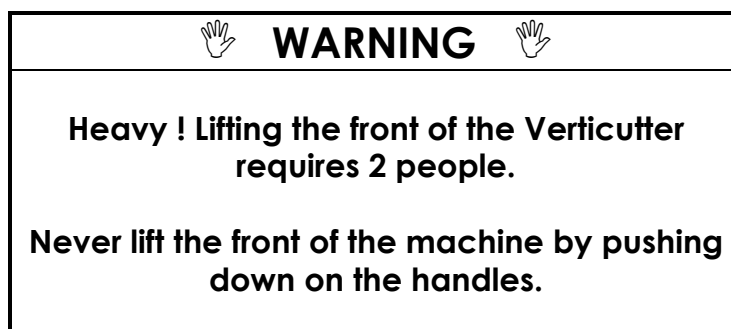

3. While holding the machine in this position securely support the front of the machine to prevent it from falling while work is being carried out.

4. When finished, gently lower the front of the machine back down to the ground.

## **6.1 Adjustments and Settings**

### **6.1.1 Rotor belts**

Correct tension on the rotor belts is assured by the tensioning spring kit on the pulley clutch rod. If, due to belt stretch, there is insufficient tension on the belts to keep the rotor blades engaged and the belts from slipping, you can tighten the nyloc nut on the end of the rod to increase compression of the spring (5181).

### **6.1.2 Gearbox Drive Belt**

Inadequate tension will cause slippage or lack of drive to the front wheels; however the belt tension required to ensure successful operation is quite low.

- \* Remove belt guard (0294)
- \* Loosen the bolt holding the V-idler pulley assembly (5556)
- \* Pull the idler pulley toward the front of the machine firmly by hand
- \* Re-tighten the holding bolt and nut.
- \* Re-fit the belt guard.

### **6.1.3 Transmission Drive Belt**

Excess tension places unnecessary strain on the transmission and causes premature belt wear.

Inadequate tension will cause slippage and a lack of drive to the front wheels; however, the tension required to ensure satisfactory operation is relatively low

- \* Remove the front cover (0005).
- \* Loosen the bolt holding the under-deck V-idler pulley assembly (5556).
- \* Pull the idler pulley toward the front of the machine firmly by hand and re-tighten the bolt and nut.
- \* Re-fit the front cover.



## **6.2 Replacements**

### **6.2.1 Blade replacement**

1. Push the pulley clutch handle (0031) fully forward.
2. Remove the belt guard (0294)
3. Remove rotor belt retaining bracket (0066).
4. Remove rotor drive belts (5550) by easing them off the pulley (5004) on the end of the rotor shaft (0047).
5. Loosen the grub screw from the eccentric locking collar on the bearing (5088) at the left end of the rotor shaft and tap the locking collar in the opposite direction to which it has been locked. Remove the locking collar.
6. Undo the bolts holding the bearings (5025,5088) at each end of the blade reel.
7. Allow the left bearing (5088) to slide along the rotor shaft to provide some free movement and gently allow the blade reel to drop free from the machine. Take care to perform this operation with a protective layer under the machine (old carpet is ideal) to protect the blade tips from any hard surface.
8. Move neutral lever to NEUTRAL.
9. Lift the rear of the Verticutter away from the blade reel, push it clear and lower the machine to the ground.
10. Slide the left end bearing (5088) from the end of the rotor shaft (0047).
11. Remove the left Nyloc nut (5089) and rotor shaft washer (0039) from the rotor shaft.
12. Remove blades (0048) and spacers from the shaft.
13. Replace blades and spacers as required, ensuring that they go back on the shaft in the same direction and configuration (i.e. counter rotating to direction of forward travel and successive blades offset one face on the rotor shaft).
14. Loosely re-position the bearing on the left end of the blade reel and place the reel under the Verticutter.
15. Orient the bearings so that the grease nipples are accessible (left bearing, nipple up; right bearing, nipple down) and loosely bolt the blade reel in place.
16. Gently lower the machine onto the blades to locate the blade reel in the machine and then firmly tighten the nuts which hold the bearings in place.
17. Raise the blades.
18. Re-fit the eccentric locking collar on the left bearing of the blade reel.
19. Re-fit rotor belts.
20. Re-fit rotor belt retaining bracket, ensuring there is clearance between the bracket and the blade reel pulley.
21. Re-fit belt guard.

## **6.2.2 Belt Replacement**

Note :Most of the stretch that the belts experience takes place in the first few hours under load conditions after they have been first installed. After fitting new belts it is advisable that the tension be checked after the first 3 to 4 hours of operation. This is especially appropriate for the rotor belts.

### **6.2.2.1 Rotor belts**

1. Push the pulley clutch handle (0031) all the way forward.
2. Remove the belt guard (0294).
3. Remove the top belt guard mounts (0514 & 0515).
4. Remove the rotor belt retaining bracket (0066).
5. Loosen the clutch pulley retainer bracket (0397).
6. Remove belts by easing them off the drive pulleys.
7. Fit new belts.
8. Re-fit rotor belt retaining bracket, ensuring there is clearance between the bracket and the blade reel pulley.
9. Re-fit the belt guard mounts (0514 & 0515).
10. Re-fit the clutch pulley retainer bracket, ensuring that when the blades are engaged, the belts do not rub on this retainer bracket.
11. Re-fit the belt guard.
12. Check that there is sufficient tension on the tensioning spring when the pulley clutch handle is operated, adjust as described in Adjustments section 6.1.1.

### **6.2.2.2 Gearbox Drive Belt**

1. Push the pulley clutch handle all the way forward.
2. Remove the belt guard (0294).
3. Remove the upper belt guard mounts (0514 & 0515).
4. Ease rotor belts from top pulley.
5. Loosen bolt holding the V-idler pulley assembly (5556).
6. Remove gearbox drive belt (5084).
7. Fit new gearbox drive belt.
8. Re-tension idler pulley as per 6.1.2.
9. Re-fit the rotor belts.
10. Re-fit the upper belt guard mounts.
11. Re-fit the belt guard.

### **6.2.2.3 Transmission Drive Belt**

1. Remove the front cover (0005).
2. Loosen the V-idler pulley assembly (5556) and remove it.
3. Roll the transmission drive belt (5528) downwards off the gearbox pulley so it is sitting between the pulley and the gearbox .
4. Rotate the belt so that the thinner profile of the belt can

- slide between the top of the transmission drive pulley (5527) and the engine base assembly (1799).
5. Now remove the belt from the gearbox pulley in the same fashion, by rotating it to the thinner profile and sliding it between the gearbox pulley and the engine base.
  6. Fit a new belt in reverse order.
  7. Re-attach the v-idler pulley assembly.
  8. Tension the belt as per 6.1.3.
  9. Re-fit the front cover.

### **6.3 Engine Maintenance**

Maintenance on the Verticutter engine should be carried out as per the manufacturer's owner's manual supplied with this machine.

To drain engine oil a slot has been provided in the Verticutter engine base assembly (1799) behind the engine and immediately under the engine oil drain plug.

1. Place a shallow (max. height 50mm) tray under the blade reel, ensuring that the rubber exclusion strip (0347) is over the tray.
2. Remove the oil filler cap and loosen the oil drain plug at the bottom rear edge of the engine until oil begins to flow. Do not completely remove the plug at this stage to avoid oil flooding over the machine's deck.
3. As oil flow diminishes remove the drain plug and allow oil to drain completely.
4. Replace drain plug and re-fill engine with oil as per manufacturer's instructions.
5. Carefully lift rear of machine with handles and push it clear of the oil drip tray.
6. Wipe away oil from deflector panel (0004) and rubber exclusion strip (0347).

## **6.4 Maintenance Schedule**

### **After first 4 hours :**

- Check tension on pulley clutch handle ; adjust as required
- Check tension on gearbox pulley ; adjust as required
- Check tension on transmission drive pulley ; adjust as required
- Check that the bolts on the handle assembly pivot points are smooth in operation and not too sloppy or binding
- Generally check for any loose nuts or fittings, especially handle mounts and blade reel retaining bolts

### **Daily : Before Use**

- Check for worn, slipping or damaged belts
- check for even tyre pressure (max. 95 kPa ; 14 psi)
- Check for worn or damaged blades
- Check for any loose nuts, bolts and fasteners
- Check engine oil for correct level

### **Daily : After Use**

- Clear rotor blades of any debris
- Clear bottom of transmission, especially unclog cooling fins
- Clear any debris generally, especially from around engine

### **Every 40 Hours**

- Grease rotor shaft bearings

### **Every 6 Months**

- Grease all bearings
- Check all belts for wear and tension ; replace if necessary
- Note : Transmission fitted to this machine is a sealed hydrostatic unit which should not require attention. However, it is recommended that the oil level in this unit be checked

### **Every 12 Months**

- Grease neutral lever mechanism at pivot points
- Grease upper and lower motion lever mechanisms at pivot points
- Check for wear of fibre washers on handle assembly mechanisms

### **Engine Maintenance**

- Maintain according to the manufacturer's schedule (see accompanying manual)

# CONTROLS

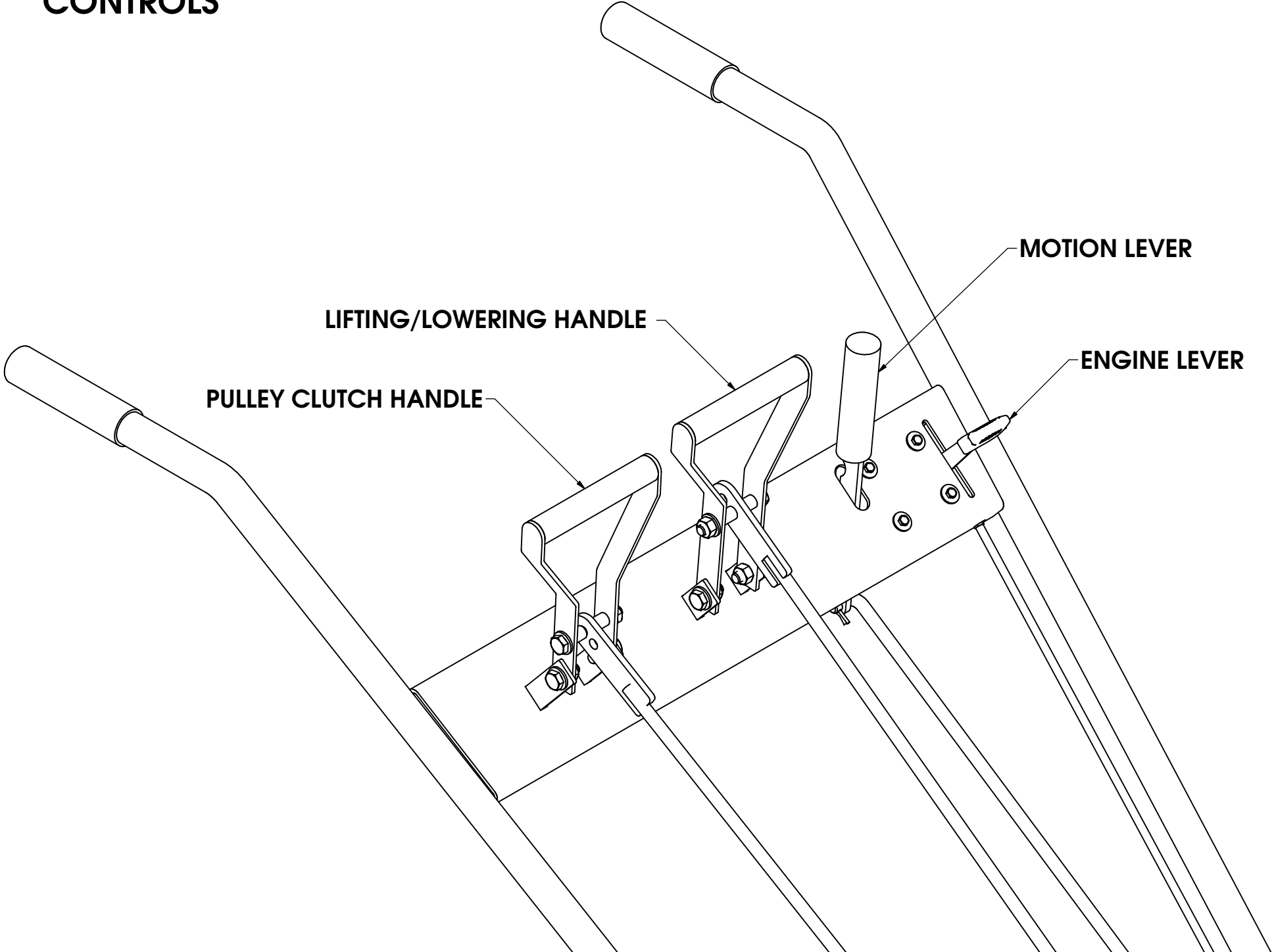

| Part Number | Description                    |
|-------------|--------------------------------|
| 0015        | Extension Shaft                |
| 0019        | Drive Idler Pulley             |
| 0020        | Tensioning Bracket             |
| 0067        | 1/4" Square x 50 mm Key        |
| 0069        | 1/4" Square x 40 mm Key        |
| 0100        | Bush (Clutch Pulley)           |
| 0293        | Support Plate                  |
| 0294        | Belt Guard                     |
| 0307        | Extension Shaft Cover          |
| 0310        | Belt Guard Mount               |
| 0315        | Gearbox Drive Pulley           |
| 0373        | Engine Shaft Bush              |
| 0397        | Clutch Pulley Retainer Bracket |
| 0514        | Belt Guard Mount (Thin)        |
| 0515        | Belt Guard Mount (Fat)         |
| 0610        | V-Idler Pulley (Small)         |
| 1799        | Engine Base Assembly           |
| 5003        | 1" Bearing (Cam Lock)          |
| 5004        | Double Belt Taper Lock Pulley  |
| 5022        | 1/2" "Glacier Bush x 3/8"      |
| 5027        | Taper Lock Bush 1" ID          |
| 5078        | Pressed Metal Bearing Flange   |
| 5084        | Drive Belt                     |
| 5117        | Engine                         |
| 5147        | Clutch Return Spring           |
| 5344        | 40mm Internal Circlip          |
| 5550        | Rotor Belt                     |
| 5556        | V-Idler Pulley Assembly        |
| 9288        | Lifting Pulley Bush            |
| 9351        | Bearing                        |

| Part Number | Description                     |
|-------------|---------------------------------|
| A           | 5/16" Flat Washer               |
| B           | 5/16" Spring Washer             |
| C           | 5/16" Internal Tooth Washer     |
| D           | 5/16" UNF Hex Nut               |
| E           | 5/16" UNF Nyloc Nut             |
| F           | 5/16" UNF x 3/4" Long Bolt      |
| G           | 5/16" UNF x 1" Long Bolt        |
| H           | 5/16" UNF x 1 1/2" Long Bolt    |
| I           | 3/8" Commercial Washer          |
| J           | 3/8" Spring Washer              |
| K           | 3/8" UNF Nyloc Nut              |
| L           | 3/8" UNF x 1 3/4" Long Bolt     |
| M           | 3/8" UNF x 2" Long Bolt         |
| N           | 3/8" UNF x 5" Long Bolt         |
| O           | 1/2" Flat Washer                |
| P           | 1/2" UNF Nyloc Nut              |
| Q           | 1/2" UNF x 2 1/2" Long Bolt     |
| R           | 3 mm Diameter x 25 mm Split Pin |

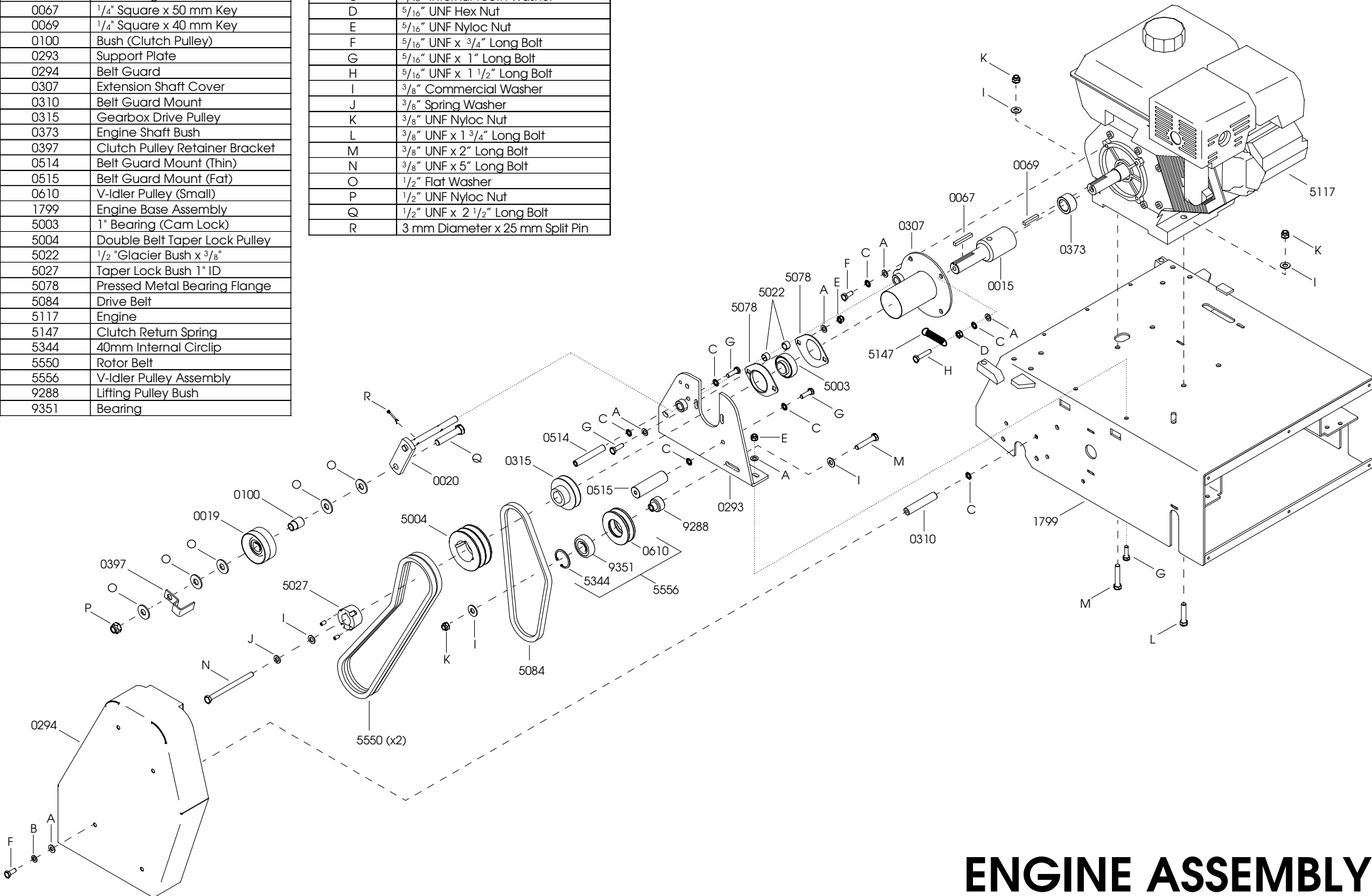

# ENGINE ASSEMBLY



| Part Number | Description               |
|-------------|---------------------------|
| 0070        | 3/16" Square x 60 mm Key  |
| 0268        | Wheel Hub                 |
| 0303        | Upper Motion Lever        |
| 0309        | Neutral Lever             |
| 0311        | Pivot Support             |
| 0477        | Gearbox Pulley            |
| 0508        | Rod                       |
| 0610        | V - Idler Pulley (Small)  |
| 1791        | Neutral Switch Mount      |
| 1795        | Neutral Actuator          |
| 1796        | Motion Lever Pivot Spacer |
| 1799        | Engine Base Assembly      |
| 1800        | Motion Lever Pivot        |
| 5068        | 3/16" x 5/8" Woodruff Key |
| 5087        | Gearbox                   |
| 5091        | 1/2" Ratchet              |
| 5092        | 20mm E - Clip             |
| 5173        | Ball Joint                |
| 5344        | 40mm Internal Circlip     |
| 5526        | Transmission              |
| 5527        | Transmission Drive Pulley |
| 5528        | Transmission Drive Belt   |
| 5556        | V-Idler Pulley Assembly   |
| 9279        | Wheel Hub - Inner         |
| 9280        | Wheel Hub - Outer         |
| 9281        | Tyre - 15 x 6.00/6        |
| 9282        | Tube - to suit 9281       |
| 9288        | Pulley Bush               |
| 9471        | 3/8" Ball Joint           |
| 9668        | Return Spring             |
| 9702        | Bearing                   |

| Part Number | Description                  |
|-------------|------------------------------|
| A           | 1/4" Flat Washer             |
| B           | 1/4" Spring Washer           |
| C           | 1/4" Internal Tooth Washer   |
| D           | 1/4" UNF Hex Nut             |
| E           | 1/4" UNF Nyloc Nut           |
| F           | 1/4" UNF x 1/2" Long Bolt    |
| G           | 1/4" UNF x 3/4" Long Bolt    |
| H           | 1/4" UNF x 2 1/4" Long Bolt  |
| I           | 5/16" Flat Washer            |
| J           | 5/16" x 1 1/2" Flat Washer   |
| K           | 5/16" Spring Washer          |
| L           | 5/16" UNF Nyloc Nut          |
| M           | 5/16" UNC x 3/4" Long Bolt   |
| N           | 5/16" UNF x 1 1/4" Long Bolt |
| O           | 5/16" UNF x 2 3/4" Long Bolt |
| P           | 3/8" Flat Washer             |
| Q           | 3/8" Commercial Washer       |
| R           | 3/8" Internal Tooth Washer   |
| S           | 3/8" UNF Hex Nut             |
| T           | 3/8" UNF Nyloc Nut           |
| U           | 3/8" UNF x 1 1/4" Long Bolt  |
| V           | 3/8" UNF x 1 3/4" Long Bolt  |
| W           | 1/2" UNF Hex Nut             |

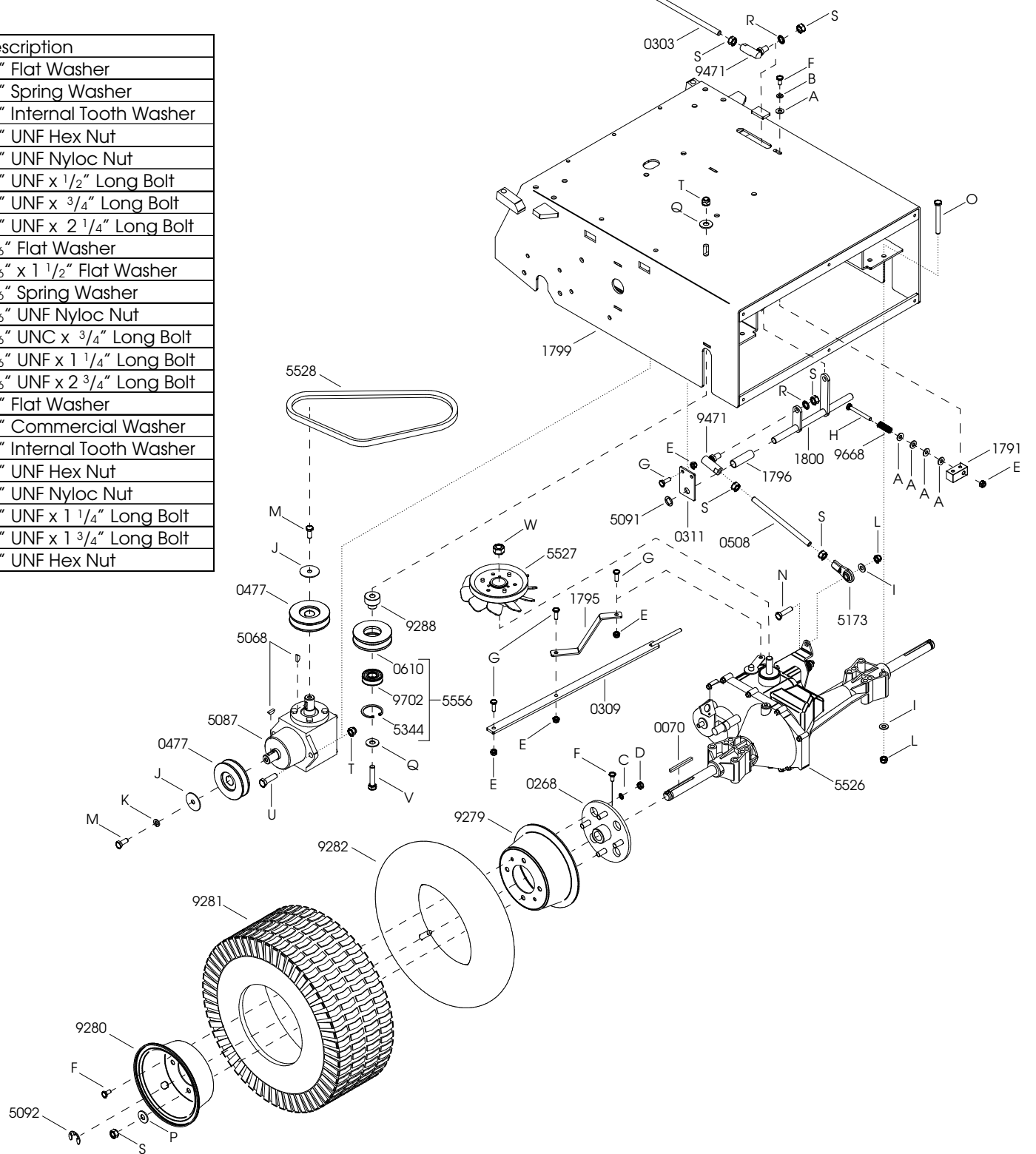

# DRIVETRAIN



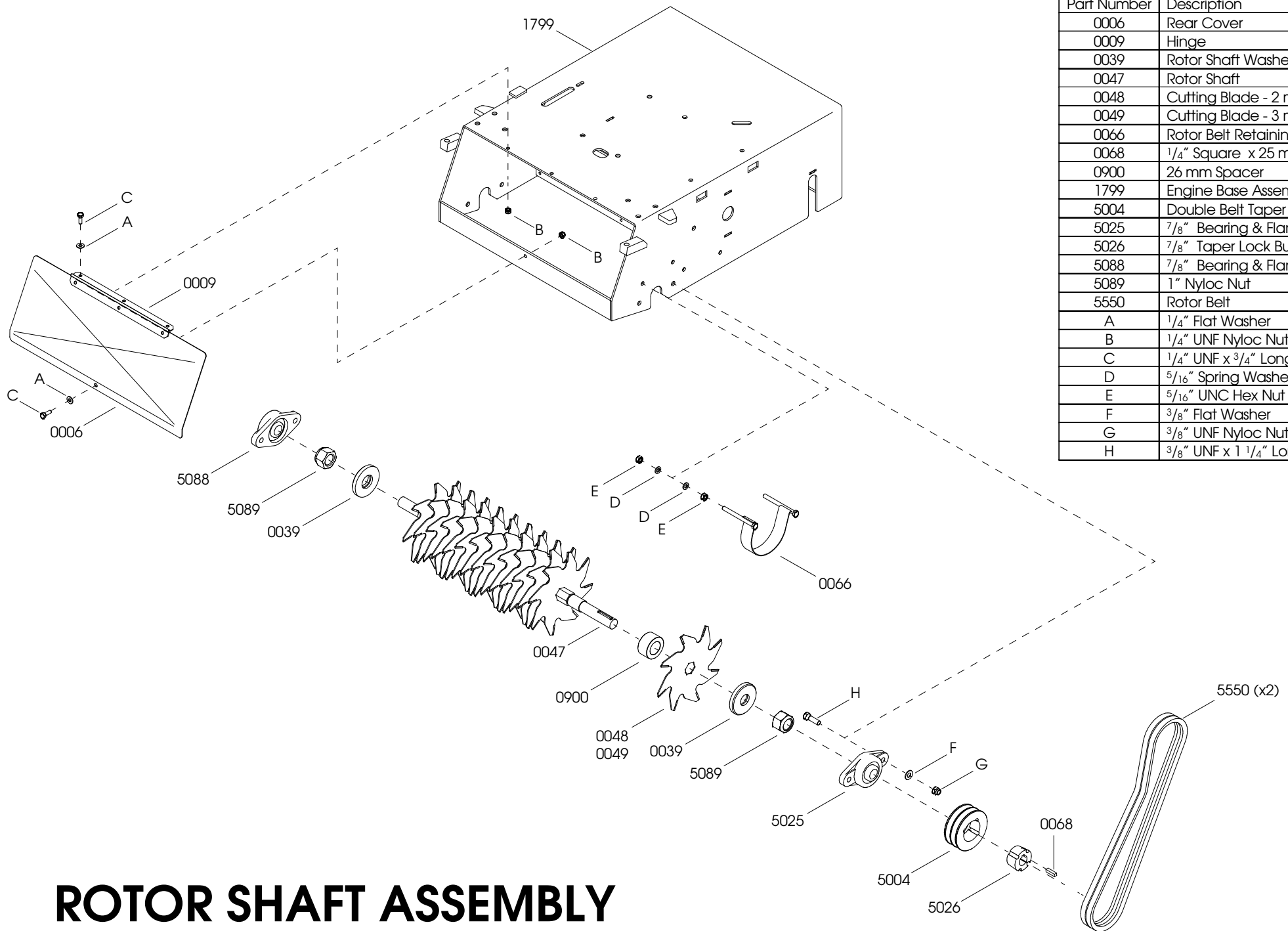

| Part Number | Description                    |
|-------------|--------------------------------|
| 0006        | Rear Cover                     |
| 0009        | Hinge                          |
| 0039        | Rotor Shaft Washer             |
| 0047        | Rotor Shaft                    |
| 0048        | Cutting Blade - 2 mm Tip (Std) |
| 0049        | Cutting Blade - 3 mm Tip (Opt) |
| 0066        | Rotor Belt Retaining Bracket   |
| 0068        | 1/4" Square x 25 mm Key        |
| 0900        | 26 mm Spacer                   |
| 1799        | Engine Base Assembly           |
| 5004        | Double Belt Taper Lock Pulley  |
| 5025        | 7/8" Bearing & Flange Unit     |
| 5026        | 7/8" Taper Lock Bush           |
| 5088        | 7/8" Bearing & Flange Unit     |
| 5089        | 1" Nyloc Nut                   |
| 5550        | Rotor Belt                     |
| A           | 1/4" Flat Washer               |
| B           | 1/4" UNF Nyloc Nut             |
| C           | 1/4" UNF x 3/4" Long Bolt      |
| D           | 5/16" Spring Washer            |
| E           | 5/16" UNC Hex Nut              |
| F           | 3/8" Flat Washer               |
| G           | 3/8" UNF Nyloc Nut             |
| H           | 3/8" UNF x 1 1/4" Long Bolt    |

# ROTOR SHAFT ASSEMBLY

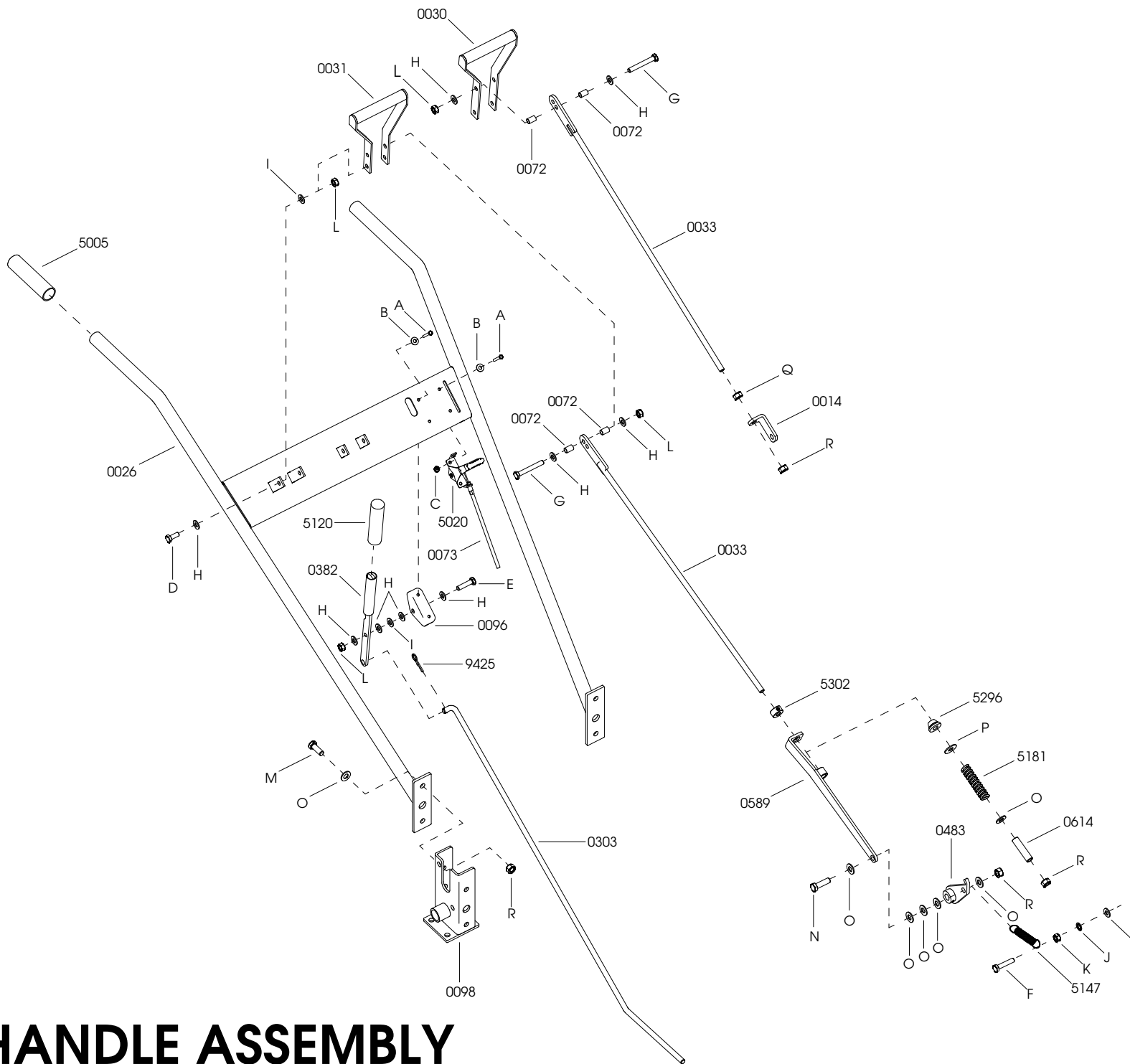

| Part Number | Description                  |
|-------------|------------------------------|
| 0014        | Rod Bracket                  |
| 0026        | Handle Assembly              |
| 0030        | Lowering Handle              |
| 0031        | Pulley Clutch Handle         |
| 0033        | Connecting Rod               |
| 0072        | Spacer                       |
| 0073        | Cable – Engine Lever         |
| 0096        | Motion Lever Bracket         |
| 0098        | Handlemount                  |
| 0303        | Upper Motion Lever           |
| 0382        | Motion Lever                 |
| 0483        | Spring Tension Arm           |
| 0589        | Spring Bracket               |
| 0614        | Slide Bush                   |
| 5005        | Handle Grip                  |
| 5020        | Control Lever                |
| 5120        | Handle Grip                  |
| 5147        | Clutch Return Spring         |
| 5181        | Tension Spring               |
| 5296        | Rubber Grommet               |
| 5302        | 3/8" Collar                  |
| 9425        | 2mm R-Clip                   |
| A           | 3/16" BSW x 3/4" Long Bolt   |
| B           | 3/16" Flat Washer            |
| C           | 3/16" BSW Nyloc Nut          |
| D           | 5/16" UNF x 3/4" Long Bolt   |
| E           | 5/16" UNF x 1 1/4" Long Bolt |
| F           | 5/16" UNF x 1 1/2" Long Bolt |
| G           | 5/16" UNF x 2 1/4" Long Bolt |
| H           | 5/16" Flat Washer            |
| I           | 5/16" Fibre Washer           |
| J           | 5/16" Internal Tooth Washer  |
| K           | 5/16" Hex Nut                |
| L           | 5/16" UNF Nyloc Nut          |
| M           | 3/8" UNF x 1" Long Bolt      |
| N           | 3/8" UNF x 1 1/4" Long Bolt  |
| O           | 3/8" Flat Washer             |
| P           | 3/8" x 7/8" Washer           |
| Q           | 3/8" UNF Hex Nut             |
| R           | 3/8" UNF Nyloc Nut           |

# HANDLE ASSEMBLY

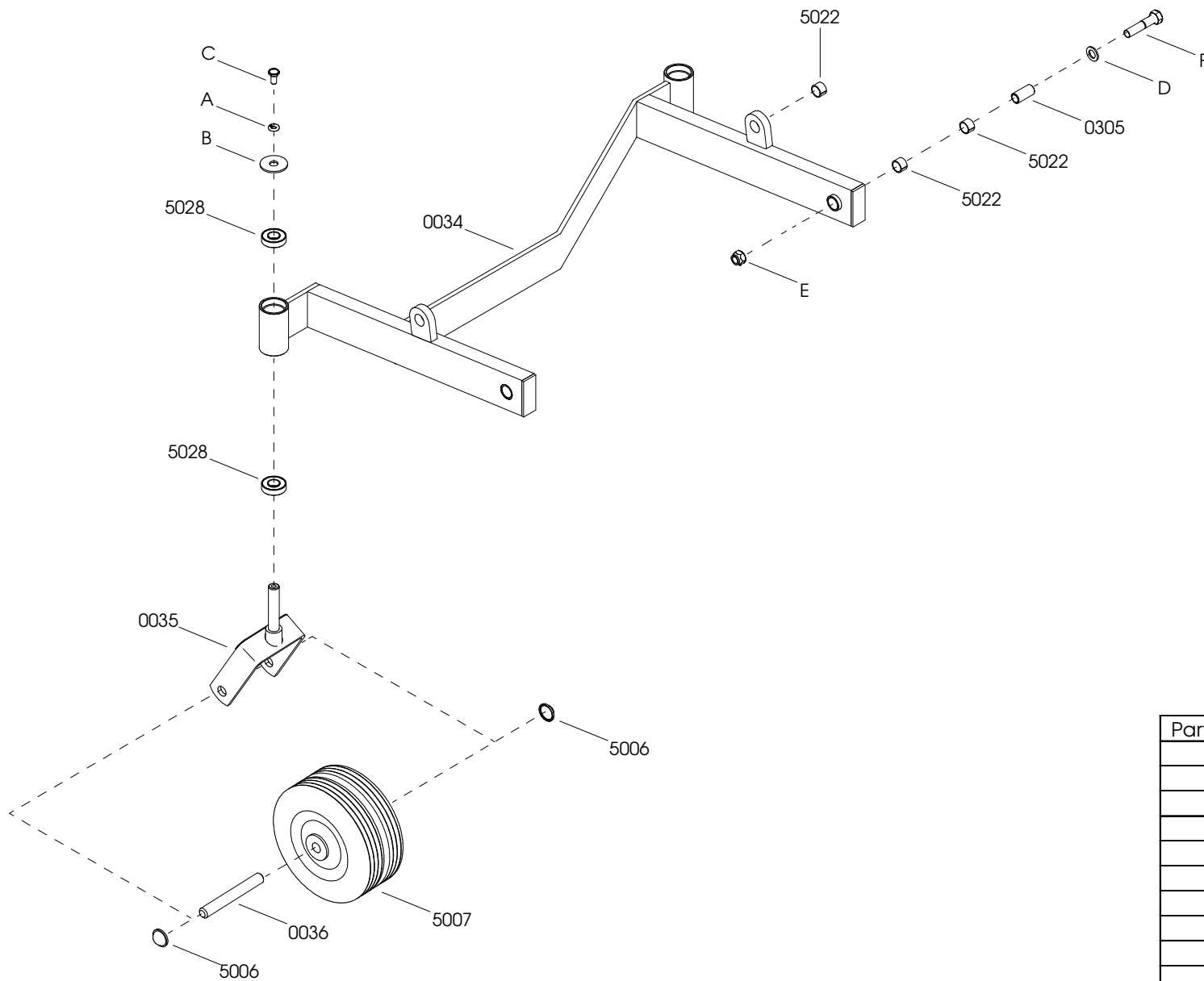

# REAR WHEEL CARRIAGE

| Part Number | Description                 |
|-------------|-----------------------------|
| 0034        | Rear Wheel Carriage         |
| 0035        | Swivel Wheel Bracket        |
| 0036        | Rear Wheel Axle             |
| 0305        | Carriage Pivot Bush         |
| 5006        | Axle Cap                    |
| 5007        | Rear Wheel                  |
| 5022        | 1/2" Glacier Bush           |
| 5028        | Rear Wheel Carriage Bearing |
| A           | 1/4" Spring Washer          |
| B           | 1/4" Mudguard Washer        |
| C           | 1/4" UNF x 1/2" Long Bolt   |
| D           | 3/8" Flat Washer            |
| E           | 3/8" UNF Nyloc Nut          |
| F           | 3/8" UNF x 1 3/4" Long Bolt |

8. Warning Decals



PART NO. 5312 – Cover Removed Decal (x2)



PART NO. 5154 – Danger Decal (x2)